

Before laying the tiles, unpack them all onto a flat surface so they recover their characteristics (tile decompression). The 10mm-thick tiles should not be laid with pins.

I. THE GROUND

The HEXDALLE® tiles should be laid on a stable, flat, clean, dry and even ground:

- concrete slab
- bitumen-coated material
- lean concrete
- surface comprising a pit run subgrade and a stabilized, compacted finishing layer of about 15cm.

II. LAYING TILES WITH PINS

Use a Stanley knife to cut some tiles in 2

Make PU 59 glue penetrate by spots



Lay the tiles in staggered rows so that they are fixed on both sides. Plan to belt the Hexdalle® tiles with rubber or concrete edgings, an existing wall, etc.

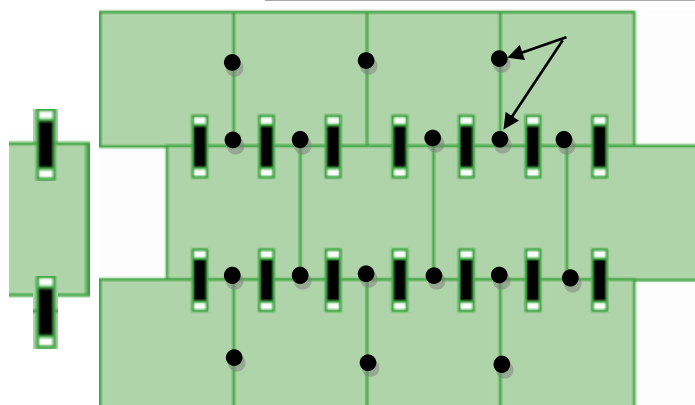

Linking by 4 plastic pins

OPTION: Linking by 8 plastic pins
Use a Stanley knife to cut some tiles in 2



Linking by 4 plastic pins (2 holes per edge)

OPTION: Linking by 8 plastic pins (4 holes per edge)

Models, drawings and names are registered. No copy or reprography is permitted without prior written authorization. This manual was reviewed in February 2016 and may be updated; please make sure this is the latest version.

FRANCE CONSTRUCTION Sols Sportifs et Techniques
ZAC des Bousquets – 165 rue de l'Initiative – F-83390 CUERS
TEL.: +33 (0)4 94 14 91 91 – FAX.: +33 (0)4 94 14 93 93
WEBSITE: www.hexdalle.com - E-MAIL: contact@hexdalle.com

2 laying options:

1. Lay the tiles on a concrete or bitumen-coated material surface, hardwood flooring, tile flooring, raised floor tiles and glue the bevelled edgings and the angles around the outside to block the tiles with our PU93 glue. You may use the reversible HEXDALLE® P1/P2 edgings instead of bevelled edgings.
2. Lay the tiles on a surface made of a pit run subgrade, 0/31.5 stabilized, compacted finishing layer and a sand layer of 0.2 or 0.5 mm size grading, 10 mm-thick. Block the tiles by laying reversible HEXDALLE® P1/P2 edgings sealed in concrete around them (Cf. edging product data sheet)

For all the options, you need to make PU59 liquid glue infiltrate spot by spot between the tiles (Cf. PU59 glue technical data sheet) and soak a few pins on the periphery.

a. 1Kg for 25 sqm

Laying example:

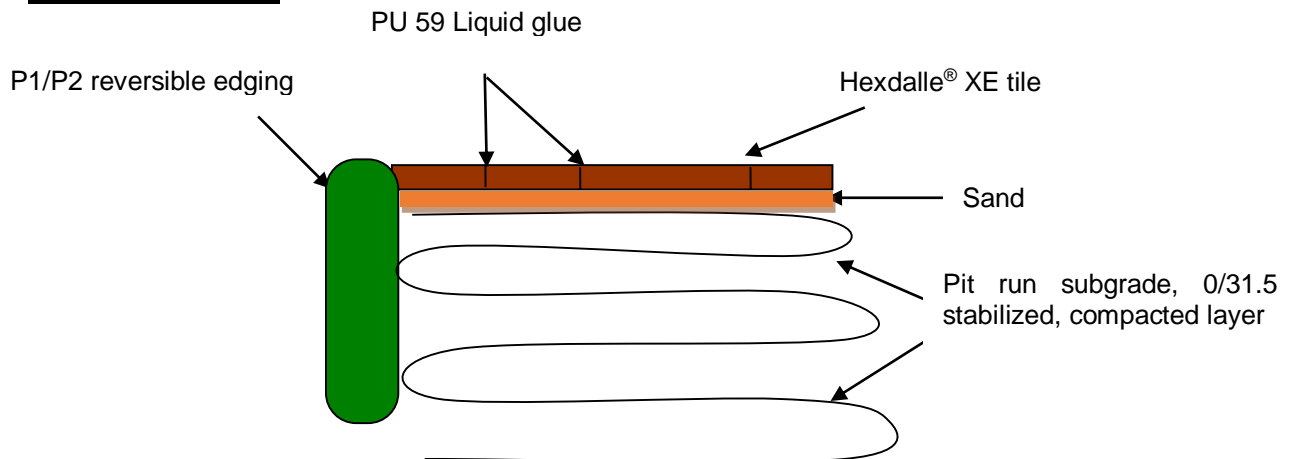

III. ADVANTAGES

- Quick and easy installation => 80 to 100 sqm / day (2 persons)
- The tiles can be laid directly onto sealants (after confirmation of the sealant product manufacturer): on roof terraces
- The tiled surface can be moved and reused

2 pins per edge on 2 opposite sides of each tile
(option: 4 holes + pins / tile)

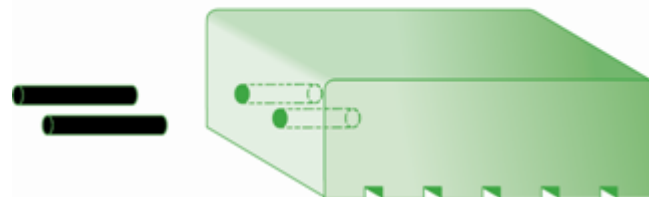

Or 4 pins per edge on 2 opposite sides of each tile
(option: 8 holes + pins / tile)

Pin

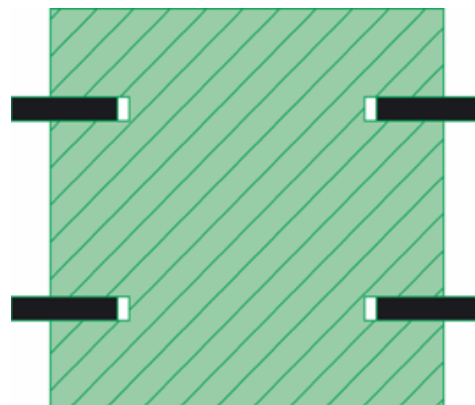

Models, drawings and names are registered. No copy or reprography is permitted without prior written authorization.
This manual was reviewed in February 2016 and may be updated; please make sure this is the latest version.

FRANCE CONSTRUCTION Sols Sportifs et Techniques
ZAC des Bousquets – 165 rue de l'Initiative – F-83390 CUERS
TEL.: +33 (0)4 94 14 91 91 – FAX.: +33 (0)4 94 14 93 93
WEBSITE: www.hexdalle.com - E-MAIL: contact@hexdalle.com

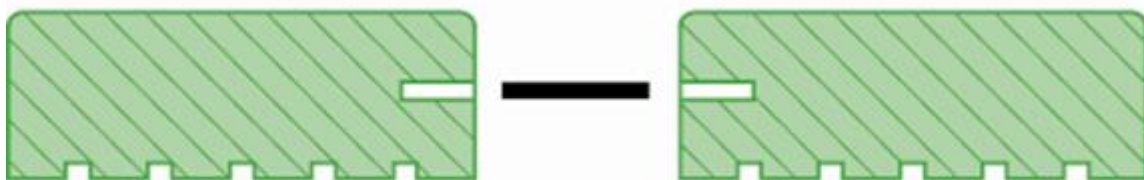

Pins are inserted into the edges of the tiles.

IV. CUTS

You may cut the tiles with a stanley knife or an electric jigsaw (stanley knife blade or mixed-tooth blade). For the game posts, use a hole saw to cut the tiles.

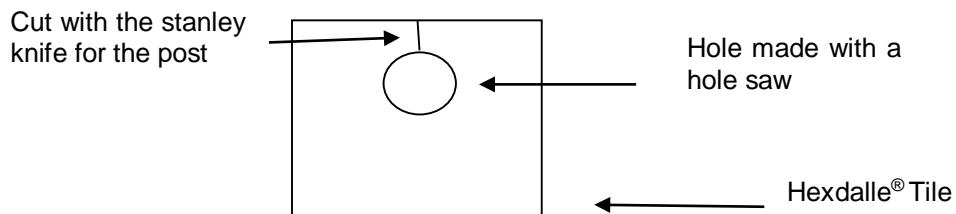

V. MAINTENANCE

HEXDALLE® can be washed with water (maximum 3 bars), or swept. Use our bactericidal, fungicidal cleaning product -CLEANDALLE FC- to clean the tiles. Wait 72 hours after laying the tiles before cleaning them for the first time.

NEVER USE PRODUCTS WITH SOLVENT TO CLEAN THE HEXDALLE® TILES.

All our HEXDALLE® tiles can be restored using a special PU 63 or PA 63 paint.

VI. TOOLS

jigsaw with cutter blades or mixed-tooth blades

Stanley knife, blades

chalk line

notched scraper

90° set square

tape measure

2-m mason's rule

1m-long aluminium angle to cut with the Stanley knife

patching product: 20-kg tub of HEXDALLE® patching (+ cement, sand, water)

sander

air blaster

empty can to be filled with water to press the tiles down

FC 41 cleaner

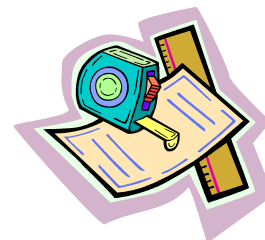

Models, drawings and names are registered. No copy or reprography is permitted without prior written authorization. This manual was reviewed in February 2016 and may be updated; please make sure this is the latest version.

FRANCE CONSTRUCTION Sols Sportifs et Techniques
 ZAC des Bousquets – 165 rue de l'Initiative – F-83390 CUERS
 TEL.: +33 (0)4 94 14 91 91 – FAX.: +33 (0)4 94 14 93 93
 WEBSITE: www.hexdalle.com - E-MAIL: contact@hexdalle.com